



## Wireless Charging Stations for Electric Vehicle IOT Used Solar Power

Chandan Kumar<sup>1</sup>, Alka Thakur<sup>2</sup>

M. Tech. Scholar, Department of Electrical Engineering, SSSUTMS University, Sehore, M.P. 466001, India<sup>1</sup>

Associate Professor, Department of Electrical Engineering, SSSUTMS University, Sehore, M.P. 466001, India<sup>2</sup>

**Abstract:** *IoT Used Solar Powered Wireless Charging Stations for Electric Vehicle As more countries are moving towards pollution free traffic, EVs are gaining more popularity across the globe. As the number of EVs increases, EV charging infrastructure will be also a basic need. A system with IoT will definitely streamline the performance of EV charging and looks the impacts. This method is helpful for transportation systems, and V2G systems. This proposed system will improve the city planning and makes the city life easy. With IoT we can easily manage the whole V2G system which will definitely saves time and money. This work is to make a smart application to connect with the grid and to know the different tariff rates of the grid. The tariff rates will have both the rate for power delivery to the grid and tariff rate for taking power from the grid. If the user is having the car battery fully charged, he can deliver some power to the grid and can earn some money. SoC is measured using the ARM Mbed controller and transmitted to cloud. The application will also displays the battery status (SoC) of the user when he comes to the grid.*

**Keywords:** *Internet of Things, SOC, Vehicle to Grid, Electric Vehicle, Vehicle to Home.*

### 1. Introduction

Batteries have become the popular form of electrical energy storage in EVs. The evolution in city transportation has boosted over the last few decades which in turn increased the growth of societies and industry. Since battery is a commonly used device for storage of energy, calculation of Status of Charge plays a vital role in the future. Nowadays, vehicles are essential in the day to day life and for industrial use as well. Sufficient effort is being done to withdraw the combustion engines by electric motors. Due to the increase in carbon dioxide (CO<sub>2</sub>) caused by the industries and transportation, the Kyoto treaty was signed. This treaty was aimed to reduce the level of CO<sub>2</sub> and has boosted the findings for new cleaner energy solutions. As a finding, Electrical Vehicles (EVs) appeared as a solution to reduce CO<sub>2</sub> emissions. Electric Vehicles are increasing day by day across the globe

[3]. When the number of Electric vehicles is increasing, there is a need to implement Electric Vehicles Charging system in parking systems or grid. Automobile major Nissan produced a vehicle-to-grid (V2G) project with Enel, a multinational power company, in the United Kingdom. Nissan has been exploring and doing researches based on V2G systems and this paper is the first of its kind in the UK and one of the company's biggest to date. The Vehicle-to-grid system function as two-way chargers and Electric Vehicle(EV) owners will have the facility to charge the vehicle or sell the excess energy (surplus) stored from their vehicle battery back to the Grid. They will earn a profit from the energy sold back to the grid, while making a markable role in grid stability. In this wide range of array of ideas, these EVs can definitely assure some gains to the energy management, eminently to supply major and important loads like manufacturing shops during power failures and any emergencies[4]. EVs bring benefits to city services and

provide indemnity for the viable energy sources intermittency. This new method is effective and more relevant owing to the fact that most of the electric vehicles are halted on an average of 91-95 percentage of their usage period, and most of the Electric vehicles are parked at home amid 9 pm and 6 am. When the EVs are plugged to the power grid, the power can discharge to or from the EV batteries (G2V and V2G). In the truancy of power grid or Electric disruption, the EV can operate as voltage parent to supply the necessary loads. This work describes the measurement and performance of EV battery in a smart grid. IoT makes smart grid to contribute the information between multiple users and thus amplifies connectivity by the help of infrastructures. Cloud storage is used for the data storage where the data is send through Internet gateway. Shows the IoT architecture. This Paper is discussing about the involvement of IoT in V2G and G2V.

## 2. Problem Definition

The essential issues that our system will fathom are to check the invalid reasons given by the drivers for the time deferral to show up at the goal on schedule. To check if any unapproved individual endeavors to get into the vehicle. To concentrate on the security of the understudies and furthermore to settle different issues like the area of the vehicle. What's more, our structure will alarm if any unapproved card is put as an alert. Guardians might want to know whether their children have reached securely on schedule and to guarantee if everything was protected during the movement and furthermore to screen their children our system will give the area and furthermore the login and logout subtleties.

## 3. Related Work

We have discovered various papers identified with the security framework. Distinctive security frameworks utilized for various purposes.[1]. This paper grants the Wireless Power Transfer (WPT) topology based on Inductive Power Transfer (IPT) with adopted Super Capacitor (SC) energy storage. The proffered topology is fitting for dynamic charging Electric Vehicles (EVs), where oscillations of energy must be concocted without placing extravagant strain on the utility grid or EV battery. [2]. Vehicle-to-layer (V2L) technology sanctions bidirectional charging of the electric vehicle (EV) and expedites power layer ancillary assistance. Nonetheless, battery packet in EV may advance in cell dynamic

variations over time. This is due to the formative complexity & electrochemical orderings in the battery pack. These diversifications may arise in V2L systems due to: earliest, additional charging and discharging successions to power layer; second, external wrecks; and third, long unfolding's to high temperatures. A fastidious reference of these diversifications is due to defective sensors. Wherefore, it can be pleaded that the battery Packs in EV are highly reliant on the monitoring of these in-cell mutations and their consequence of propagation with each incriminated component. In this article, a prognostication based scheme to showcase the health of variation induced sensors is proposed. First, a propagation model is refined to predict the in-cell mutations of a battery pack by intelligent the covariance using a median based expectation. Second, a surmise model is developed to distinguish and divide each variation. This is obtained by deriving a conditional probability-based density function for the computations. The proposed monitoring framework is evaluated using experimental measurements collected from Lithium-ion battery pack in EV.

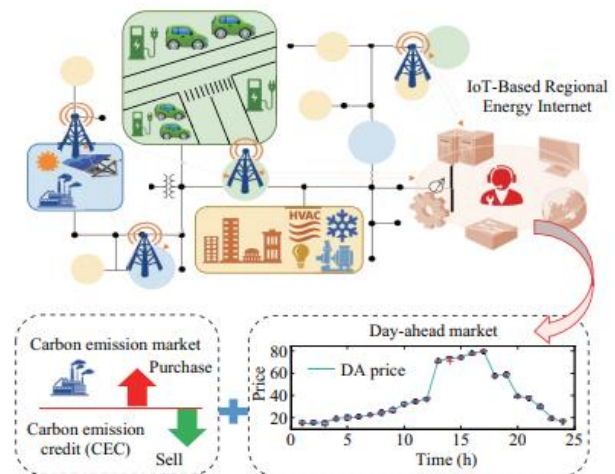

Fig.1. Schematic of an IoT-based regional energy internet

The major difference between both the possible MPC's is the capability of isolating PV panels from the grid. The depicts that, both the topologies adapt a central DC-link available within the DC-DC converter. For efficient power flow management, the DC link voltage rating must be higher than the peak voltage of the system. In a non-isolated DC/DC converter is adapted for achieving maximum power from the PV array. A high-frequency DC-DC conversion is adapted for EV charging station by adding a high-frequency transformer between the conversion processes as per proposed energy management strategy. In order to design

the proposed system configuration, the flow of the power between the four main elements in this system needs to be explored. The main elements are the connecting electrical grid, the PV sources, the battery storage and the EVs charging load. The decision on the need for a bi-directional power flow power electronic system, along with their sizing requirements, can be decided based on power flow management. Consequently, the research attempts to solve the power flow management problem by introducing their applicability on the studied application. Conventionally, the power flow in a grid-connected PV/battery system is predefined by heuristic rules that consider the load demand, the PV insulation levels and the peak utility hours. However, a dynamic grid tare complicates the solution of the proposed system further. In a dynamic grid tar system, the operation of the PV/battery system using the simplified heuristic rules will provide running cost solutions that largely deviate from the minimal cost operation. Thus, the research in this area has taken on an accelerated path battery charging or discharging current, where the objective is to maximize the contribution of the hybrid system to the grid. The proposed technique in Reference assumes there is no dispatch cost associated with the PV/Battery output power. This leads to the negligence of the battery degradation cost and its advisable operating conditions. Additionally, the formulation of the problem is limited to a thermally based electrical grid system. Where the battery energy storage is integrated into the renewable energy system in order to enable the PV source to act as a dispatch able unit on an hourly basis. The objective of the battery storage utilization system is sensitive to solar power forecasts. From the above literature, it is observed that, initially, the problem formulation should account for the aging factor of the battery in order to extend the battery lifetime, and thus, increase the system reliability. The desired power flow management topology has to accommodate non-linear functions. This allows the generalization of the developed topology on different operating scenarios. An online error compensation stage has to be included in the topology to allow the system to operate effectively at mismatching conditions and forecasting deviations. Lastly, the online optimization stage should be designed to operate with low computational time, which makes it easily integrated into real-time controllers. Study regarding intelligent energy management strategy and dynamic power allocation is required in order to overcome these drawbacks and achieve the proposed optimization.

## 4. Results

The proposed off-grid charging station (OGCS) consists of a 24 kWp PV generation for the EV battery of 15 kWh capacities. Additionally, an ESS of 15 kWh capacities is added to the proposed system. It has been used as an emergency supply to the EV batteries in case of low PV generation and stores the energy during the time of high PV generation. Further, the system has been designed in MATLAB/Simulink. The performance of the proposed system analyzed by considering three modes. These modes are categorized such as EV battery charging (i) with OGCS in absence of ESS, (ii) with OGCS in the presence of ESS and (iii) with ESS in the absence PV generation. Every mode is analyzed for 12 s. on the basis of charging rate (C-rate) which replicates the power demand at a time of EV battery. Initially, the EV battery is charged at 0.5 C-rate for 3 s. and a step of 0.5 C-rate is added at every 3 s. up to 12 s. whenever the power demand increases or decreases in terms of C-rate, the connected ESS and PV generation are participating accordingly in the aforementioned modes. The performance of every mode is discussed in terms of power, SoC, terminal voltage and current of the batter.

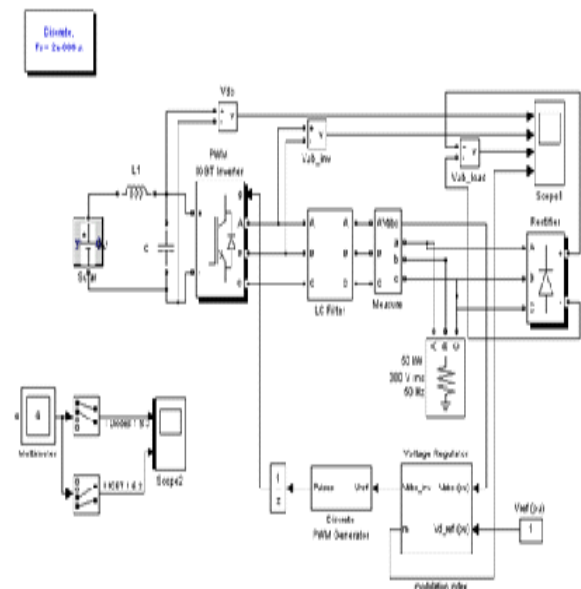

Fig.2. Modeling of on-grid PV array converter and inverter set.

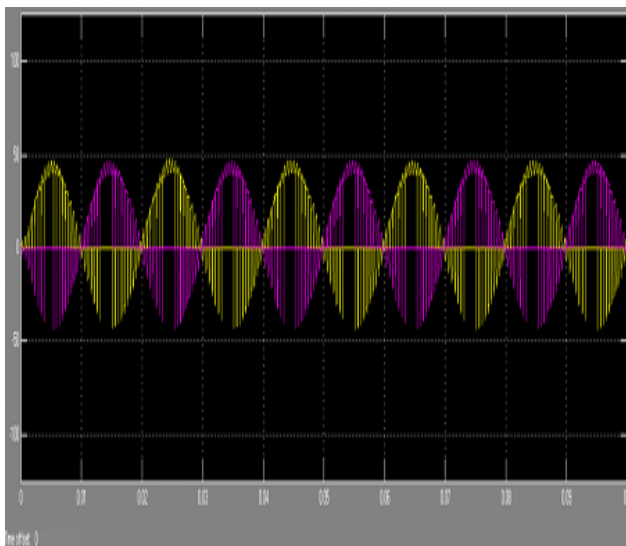
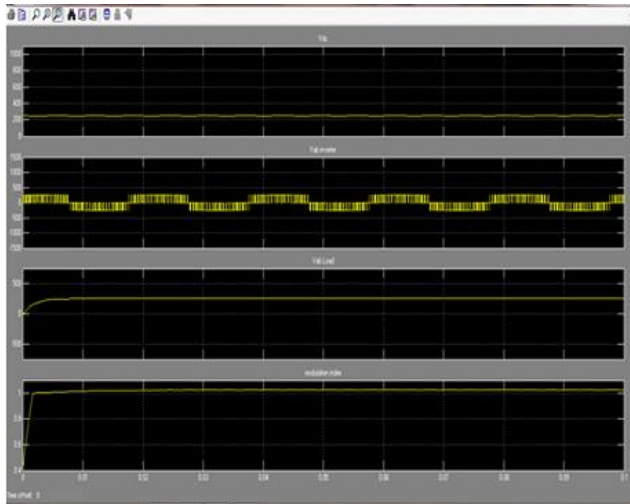

Fig.3. Modeling of on-grid PV array converter and inverter set Voltage ,Current and pulse display graph.

conversion system, PV array, maximum power point tracking (MPPT) controller, unidirectional DC/DC converters for PV array, DC-AC inverter connected to grid, and bidirectional DC-DC converter for providing charging to EVs. In this paper , the charging station is constructed in such a way that it can handle 10 EVs charging points. It is noted that the proposed charging stations can switch vehicle-to-grid (V2G) connection. An automatic system is incorporated to manage the charging of EVs and discharge the electric energy through the grid when the load demand of the grid is high.

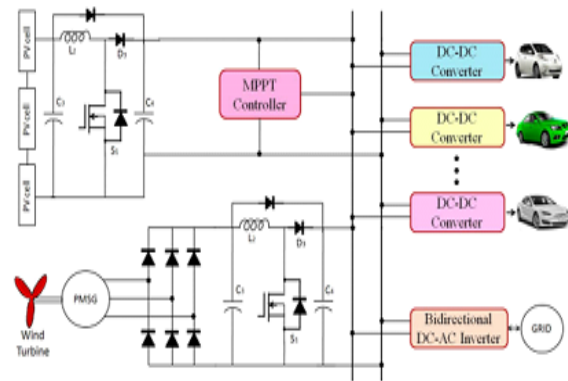

Fig.4. Implementation of the proposed charging station

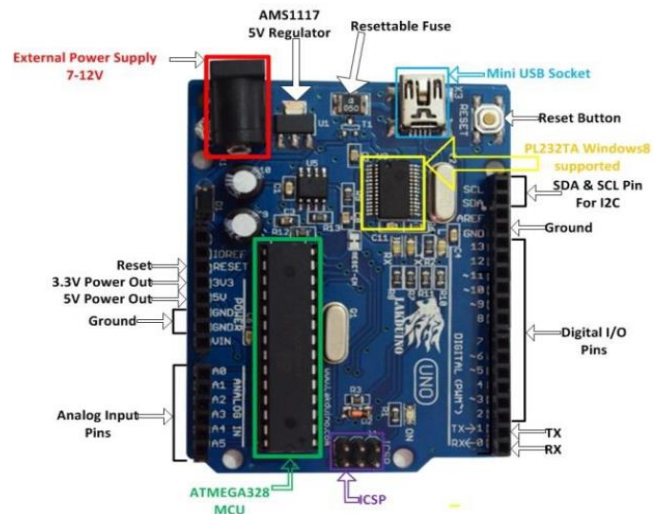

Fig.5. Arduino uno

Smart charging will play an instrumental part in the role of future cities, and that charging infrastructure will move away from a 'socket in the street', to an IOT connected device. EV charging infrastructure should serve as a multipurpose asset, from digital advertisement and Wi-Fi to energy balancing, helping to both future proof and increases a charging network commercial viability. A system with IOT will definitely improve the performance of EV charging and looks the impacts. This work is to make a smart application to connect with the grid and to know the different tariff rates of the grid. The tariff rates will have both the rate for power delivery to the grid and tariff rate for taking power from the grid. If the user is having the car battery fully charged, he can deliver some power to the grid and can earn some money. Here we mainly focus on the IoT part of determining the SOC value and sending the data to



the IO. The user can view the data in the App. Also, the user can locate the nearby charging station locations using the app. Once the user knows about the status of his car battery Hardware components Arduino In this, main processor is microchip ATmega328p microcontroller. The power supply is given by an USB cable. The input voltage of Arduino ranges between 7V to 20V. This Arduino is programmed by using software called Arduino Integrated Development Environment. By default ATmega 328 will be programmed Status of charge = Initial SOC –Nominal capacity of battery. The battery used in this is Lithium- ion battery 12V, 7Ah. For sensing the current passing through the battery a transducer called LTS25NP is used. Li-ion Battery 12V-7Ah. This transducer puts an impression on Arduino microcontroller. A code is compiled into the Arduino microcontroller for the calculation of SOC. The computed data will be sent to an ESP 8266 Wi-Fi module as analog signals. Then the ESP 8266 is connected to the cloud by using the cloud IP address through the internet. There after all data can be stored in the cloud.

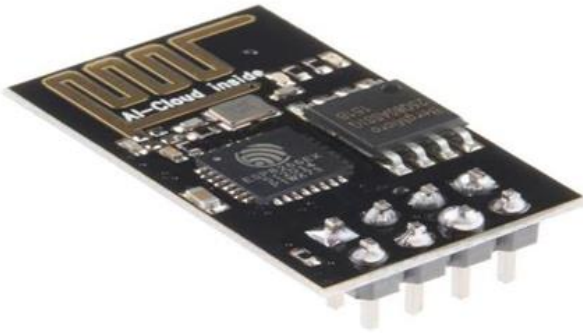

Fig.6. ESP 8266 Wi-Fi module

The status of the battery will be computed by the Arduino uno (microcontroller), then the computed data will be stored in cloud, where the ESP8266 acts as intermediate device between the microcontroller and the network. The stored data can be accessed by the cloud using certain applications like Adafruit, MQTT dash board etc. Hence the user will get to know about his car's battery status and also he can provide excess amount of charge to any other applications, by knowing the status of the battery. Power management by analyzing the status of the battery also he can decide, to provide the excess amount of charge to other applications. The main aim of this thesis is to minimize the difficulty in building charging stations for electric vehicles. By using above mentioned methods, charging stations can be built easily and can be maintained in a well manner for domestic purposes.

## 5. Conclusion

The implementation of Smart Grid devices in the utility grid will influence vast modification in grid management and usage of electric power in upcoming years. The smart grid, when introduced to Internet of Things technology makes every device active and brings them online. The detailed structure of smart grid is discussed in this work. With Electric Vehicles (EVs) being an integral part of the sustainable development, mass unplanned deployment will affect the grid in a negative way. The impact of EVs on the grid is discussed and to mitigate this impact by facilitating smart charging, a complete optimization model is presented aimed at maximizing the trade revenue for an aggregator of EV. The integration of distributed generation necessitates the deployment of energy storage system. EVs as dynamic energy storage system are good prospect due to their better electrical characteristics, but can undergo deterioration due to extreme usage. To alleviate the possibility of damage, an accurate real-time monitoring of a battery pack is implemented in this thesis to increase their lifespan and to protect the equipment they power. A less complex and easy to implement, i.e., enhanced coulomb counting technique is employed. The Enhanced Coulomb counting method incorporates self-discharge, temperature dependency and degradation due to aging otherwise absent in popular Coulomb counting method. The estimated State of Charge, State of Health with operating temperature is made available in real time to the user on a remote basis in the form of messaging communication. The dynamic nature of the system necessitates the use of a lightweight communication protocol, for which MQTT is apt. A new recharging mechanism for electric vehicles is proposed using solar and wind energy. The usage of EV is directly affected by the present charging technique. Recharging stations are necessary for longer drive vehicles and it is commonly used in few countries. The traveling distance depends on the capacity of energy storage present in the vehicle. The recharging stations are needed for long distance travel. In this paper, we have introduced a new hybrid renewable charging mechanism for EVs. A simulation model has been developed using MATLAB-Simulink and the performance of solar and wind energy has been studied. Various parameters of the solar module have been verified under different irradiation level. The studied under different loading condition. Finally, the hourly load of EV versus generated electricity has been analyzed. From the output generated by the hybrid system, we strongly say that the proposed provides enough power for recharging the electric vehicle and the time taken for charging can be avoided by battery swapping At last, we are concluding that



this approach reduces the pollution and increase the usage of EVs as a result creating pollution free environment. In this thesis, is PEV charging station is proposed to charge the EV battery. This minimizes the grid burden and increases the EVs utilization at remote locations by using the PV. In thesis, the power to charge the EV battery during the absence or reduced sunlight. Further, a constant current method is used to charge the EV battery as well as pollution-free transportation. A charging process undergone for electric vehicles in parking lot areas. It allows us to evaluate a wide range of Plug-in Hybrid Electric Vehicles (PHEVs) and Plug-in Electric Vehicles (PEVs) charging scenarios and the corresponding control strategies. In addition, this allows us to explore a variety of communication technologies for a PHEV/PEV charging facility. The charging scheme used here is monitored by Arduino board. Some vehicles are parked during the day at workplace parking garages and can be charged from the solar energy using Photo-Voltaic (PV) cell based charging facilities. The charging with solar energy helps to reduce the emissions from the power grid but increases the cost of charging. Moreover, it offers more flexibility to prepare for the emergence of new technologies (e.g., Vehicle-to-Grid, Vehicle-to-Building, and Smart Charging), which will become a reality in the near future. The simulation results provide a general overview of the impact of the proposed charging scenarios in terms of voltage profiles, peak demand, and charging cost. Renewable energy, systems engineering, and electric vehicles. On top of this, we both feel that we have improved time management organization One thing we would like to emphasize is how unpractical the system is with just one solar panel and battery. We discovered that it could take almost 1 hours under direct sunlight to fully charge of daylight and those hours of sun aren't efficiently collected by a solar panel, even with a dual-axis tracker built into the system because it will not likely achieve direct sunlight. This means that this system.

## References

- [1] T.S.Biya, Design and Power Management of Solar Powered Electric Vehicle Charging Station with Energy Storage System, Electronics Communication and Aerospace Technology, ISBN: 978-1-7281-0167-5 IEEE, ICECA 2019.
- [2] Esha Sharma, IOT Enabled Smart Charging Stations for Electric Vehicles, Journal of Telecommunication Study, Volume 4 Issue 2,2015.
- [3] Arun kumar P, IOT Enabled smart charging stations for ElectricVehicle, International Journal of Pure and Applied Mathematics, Volume 119 No. 7, 247-252, 2018.
- [4] Piyush Tajane, Solar and wind powered electric vehicle charging using wireless charging lane, International Journal of Advanced Research in Science, Engineering and Technology, Vol. 6, Issue 12 , December 2019.
- [5] Xiao Lu, Ping Wang, Wireless Charging Technologies: Fundamentals, Standards, and Network Applications, IEEE COMMUNICATIONS SURVEYS AND TUTORIALS, TO APPEAR,2015.
- [6] Mohammad Asaad, IoT enabled Electric Vehicle's Battery Monitoring System, North China Electr., vol. 2, pp. 59-63, 2010.
- [7] K. Saadullah, A. Aqueel, A. Furkan, S. S. Mahdi, S. A. Mohammad, and K. Siddiq, "A comprehensive review on solar powered electric vehicle charging system," pp. 54-79, Dec 2017.
- [8] Photovoltaic (pv) pricing trends: Historical, recent, and near-term projections," pp. 1- 30, 2012.
- [9] Z. Jiang, H. Tian, M. J. Beshir, S. Vohra, and A. Mazloomzadeh, "Analysis of electric vehicle charging impact on the electric power grid: Based on smart grid regional demonstration project los angeles," pp. 1-5, 2016.
- [10] S. Habib, M. Kamran, and U. Rashid, "Impact analysis of vehicle-to-grid technology and charging strategies of electric vehicles on distribution networks: A review," pp. 205- 214, 2015.
- [11] J. McLaren, J. Miller, E. O'Shaughnessy, E. Wood, and E. Shapiro, "Emissions associated with electric vehicle charging: Impact of electricity generation mix, charging infrastructure availability, and vehicle type, 2016.
- [12] <http://www.ieso.ca/learn/ontario-supply-mix/Ontario-energy-capacity>.
- [13] M. H. Amini, M. P. Moghaddam, and O. Karabasoglu, "Simultaneous allocation of electric vehicles' parking lots and distributed renewable resources in smart power distribution, networks," pp. 332-342, 2017.
- [14] M. F. Shaaban and E. F. El-Saadany, "Accommodating high penetrations of pevs and renewable dg considering uncertainties in distribution systems," Jan 2014.
- [15] W. Su, J. Wang, and J. Roh, "Stochastic energy scheduling in micro-grids with intermittent renewable energy resources," Jul 2014.
- [16] M. E. Khodayar, L. Wu, and M. Shahidehpour, "Hourly coordination of electric vehicle operation and volatile wind power generation in SCUC," Sep 2012.
- [17] S. J. Gunter, K. K. Afridi, and K. K. Perreault, "Optimal design of grid-connected pev charging systems with integrated distributed resources," Jun 2013.
- [18] L. E. Erickson, J. Cutsor, and J. Robinson, "Solar powered charging stations," pp. 23-33, 2017.
- [19] <http://www.envisionsolar.com>
- [20] R. H. Ashique, S. Zainal, J. B. A. A. Mohd, and A. R. Bhatti, "Integrated photovoltaic grid dc fast charging system for electric vehicle: A review of the architecture and control, Dec 2017.