



# Speed control of three Phase Induction Motor and high step up Resonant Switched capacitor Converter

Lankit<sup>1</sup>, Nitin Choudhary<sup>2</sup>

M. Tech Scholar, Department of Electrical & Electronics Engg. KIST Bhopal (India)<sup>1</sup>

Assistant Professor, Department of Electrical & Electronics Engg. KIST Bhopal (India)<sup>2</sup>

**Abstract:** In this paper a new high step up DC to AC converter is introduced controlled with PWM technique. The output three phase AC voltages is fed to three phase induction motor controlled by vector control. The converter is connected to low voltage renewable source like PVA or battery. The low voltage is stepped up to higher voltage using the proposed converter with coupled inductor and resonant switched capacitor. Because of the synchronous rectification Boost unit and multiple coupled-inductor-SC units the structure can therefore be easily extended for ultra-high voltage gain. The power electronic switches are operated with soft switching with reduced voltage stress increasing the reliability of the converter. MOSFET power electronic switches are used to control the circuit output voltage with high switching Frequency in the range of 100 kHz. This high switching frequency reduces the ripple in the DC voltage output reducing the Harmonics in the AC voltage side of the converter. The AC voltage output of the converter is controlled by vector control with speed reference in turn controlling the induction machine. The complete modelling is carried out in MATLAB Simulink environment with discrete analysis of the circuit. The graphs are plotted with respect to time and are explained using GUI environment.

**Keywords:** Magnetic Coupled-inductor, dc-dc converter, soft switching, switched-capacitor, PV Array, vector control, Induction motor, MATLAB 2016.

## 1. Introduction

VARIOUS low dc voltage sources and energy storage devices, such as photovoltaic (PV) cells, fuel cells, battery, and super capacitor, are usually need to be boosted to a high ac voltage level for industrial applications [1]. One solution is to use step-up multilevel inverters to convert them to a high ac voltage directly [2]. Another mean is to employ high step-up dc-dc converters to first boost them to a high dc level and then to connect with a full bridge. For high step-up dc-dc conversion, transformer-based switched-mode power supplies (SMPSs), such as Fly back and Forward converters, etc., are normally applied due to their simple structure. In recent years, many novel high step-up dc-dc converters have been developed by utilizing one or several of the following techniques: switched-capacitor (SC), also known as voltage-multiplier or charge pump, switched inductor, tapped inductor, and coupled inductor. A high stepup converter and a step-down version integrating buck/boost and SC techniques are presented in [8] and [9], respectively.

A high step-up converter based on switched-inductor structure. With the combination of SC and switched-inductor techniques, a series of single-stage SC inductor converters is introduced in among these new techniques, the combination of coupled inductor and SC is most widely adapted for high voltage gain. Their common features are that the voltage conversion ratio can be regulated in pulse width modulation (PWM) mode; less active switches and magnetic components are employed. For instance, only one active switch and one coupled inductors are employed in the converters of implement high voltage conversion ratio. In this thesis we will talk about two application of high advance up dc to ac converter they are ,(a) the displaying of grid associated PV frameworks, ,(b) dynamic model of the induction motor created utilizing Simulink/MATLAB that can be utilized to think about the transient conduct of a motor-drive. The goal of this work is to investigate the exhibition and dynamic conduct of grid associated PV frameworks, and drive application.

## 2. Problem Identification and Objectives

### 2.1 Problems Statement

Induction motors are used in almost all industries. Where the rotating magnetic field of the stator cuts the stationary rotor conductors, an emf is induced and this is called principal of induction. Induction motor works on this principal. Induction motor has a significant place in industrial drive application. Almost every industries use AC power, whereas the ac power is used in distribution, generation and transmission. Earlier, for the speed control applications DC motors are used rather than induction motors because speed control of motor was difficult. Due to the advance in power electronics and semi-conductor switches the speed control of induction motor are possible, mostly variable frequency drive (VFD) are used in industries. The advantage of using these methods are we can save energy as well as the life of the motor.

One of the diminishing factors of the electrical field is that the demand of electrical power is increasing each day. The gadget oriented and luxurious life led by the society has resulted in high usage of electrical power, where the generation of the power and demand of the power are not in proportion. So we need to find other solution to meet up with the demand. If an efficient converter is linked with renewable energy sources like solar cells, wind mill etc. We can drive various machines in industries with these converters. Which will be more effective and energy saving.

For high step-up dc-dc conversion, transformer-based switched-mode power supplies (SMPSs), such as Flyback and Forward converters, etc., are normally applied due to their simple structure. In recent years, many novel high step-up dc-dc converters have been developed by utilizing one or several of the following techniques: switched-capacitor (SC), also known as voltage-multiplier or charge pump, switched inductor, tapped inductor, and coupled.

In this report, resonant switched capacitor is fed with three phase induction motor. Motor is driven through a pv array, a DC-DC converter (resonant switched capacitor) a voltage source inverter through which three phase induction motor is fed.

The control methods for induction motors can be divided into two parts: scalar control and vector control strategies. Scalar control is relatively simple method compared to vector control. The purpose of the scalar control technique is to control the magnitude of the chosen quantities. For the Induction Motor (IM) the technique is used as Volts/Hertz constant. Vector control is more complex technique than scalar control, the evolution of which was inexorable, since scalar control technique cannot be applied for controlling systems with dynamic behavior. The vector control technique works with vector quantities,

controlling the desired values by using space phasors. It is also known as field-oriented control because in the implementation the identification of the field flux of the motor is required. In most of the methods there is estimation of rotor flux angle and parameter tuning in FOC. In FOC, any controller is easily implemented and can approach desired system response.

## 3. Methodology

Figure 1 shows a block diagram of proposed converter. The proposed converter consist of low level input dc voltage, , high step up DC-DC converter, renewable energy sources or PV ,3-phase inverter and induction motor drive . The combination of coupled inductor and SC is most widely adapted for high voltage gain. Specifically, multiple novel high step-up converters based on coupled-inductor and SC structure. The high step up DC-DC converter is used to get high output voltage from low input voltage and this high step up output voltage is given to the 3- inverter. This inverter is converted the high step up DC voltage into 3-phase AC voltages and given to the induction motor .speed of induction is controlled by vector control technique. Vector control is that it increases the efficiency of ac drive or induction motor .it offer higher more dynamic performance in the case speed and torque controlled induction motor drive. Here vector controller is fed space vector pulse width modulation .space vector technique is that it reduce the harmonics of sinusoidal pulse.

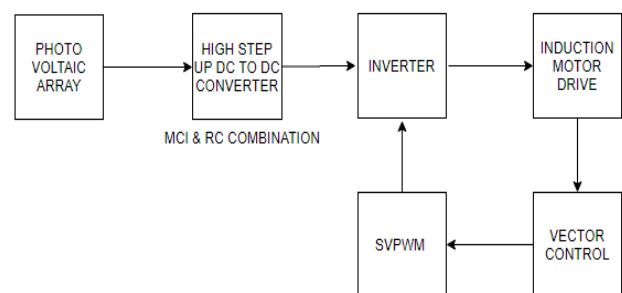

Fig 1 Block Diagram of Proposed System

### 3.1 Simulation Model of high step up dc to dc converter with R-Load

Fig.2 show the simulation Model of high step up dc to dc converter connected with linear R--Load It is a combination of Resonant switching capacitor and magnetic coupling inductor. Due to resonant switching capacitor, reduce charge sharing loss in sc operation ,increased power density and provide wide output range with higher efficiency.

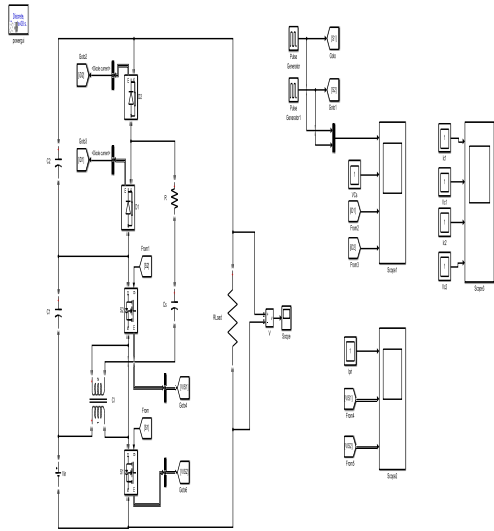

Fig 2 Proposed Model of high step up dc to dc converter with R-Load

### 3.2 Simulation model of speed controlling of induction motor using the vector control technique

The Simulation of Vector Control of Induction Motor is done by using MATLAB/SIMULINK. The simulation model High step up DC-DC converter with vector control induction machine is shown in fig, no 3. It is a combination of PV, resonant switching capacitor and magnetic coupling inductor, three phase bridge level inverter, vector controller, PWM generator. The speed control of the induction machine is done using vector control technique.

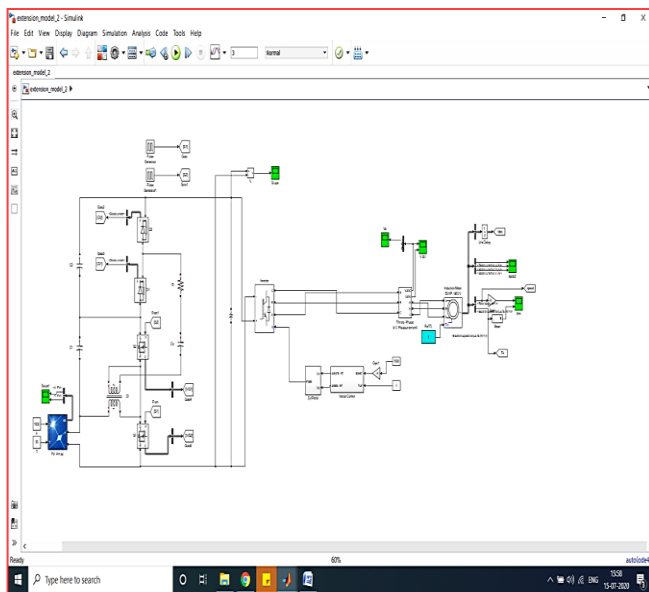

Fig. 3 simulation model of speed control of induction motor using vector control.

## 4 Results & Discussion

To high step up dc to dc voltage using resonant switching capacitor coupled inductor and soft switching.

It is very clear the from fig no.4 when 120 dc voltages injected to resonant switching circuit then output voltage is generated 200 constant dc voltages.

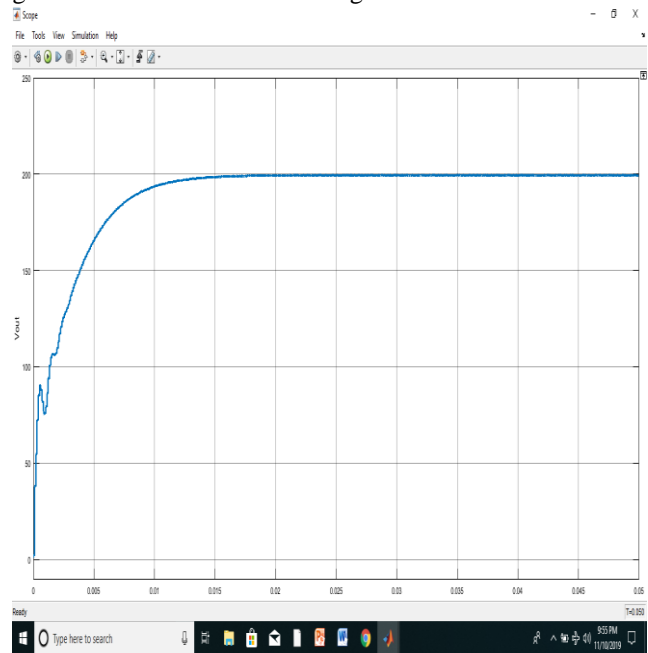

Fig. No. 4 Output voltage for high step up converter with R load

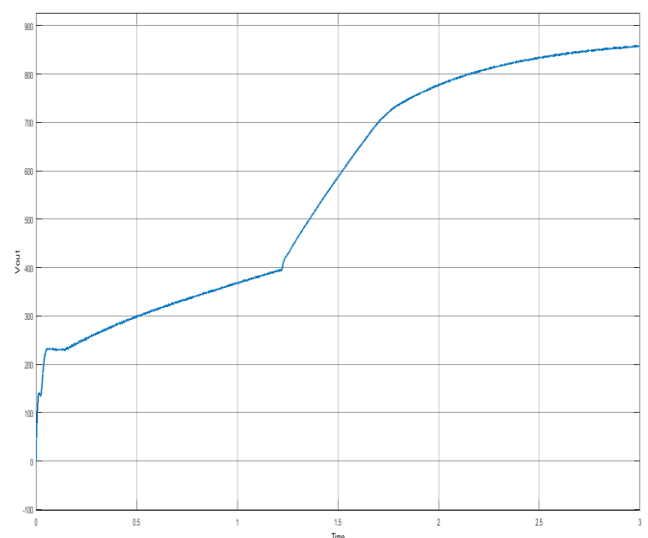

Fig. 5 DC voltage output of the proposed converter when connected to induction machine

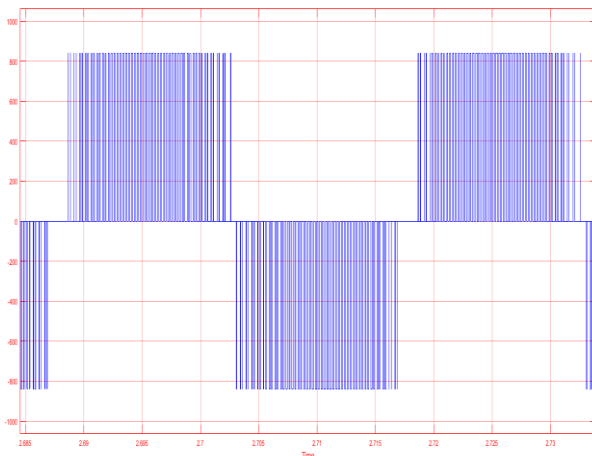

Fig. 6 Inverter voltage of phase A

The above (fig. 6) are the currents and single phase inverter voltage of the three phase induction machine controlled by vector controller with SVPWM.

## 5 Conclusion and Future Scope

The proposed converter with PVA input is connected to three phase induction machine with high gain voltage output from the converter. The voltage at very low level 120V from the PVA is stepped up to a high voltage of 700V by the 'High Step-up PWM DC-DC Converter with Coupled-Inductor and Resonant Switched Capacitor' circuit. The high stepped up DC voltage is converted to three phase AC voltage using inverter making the AC voltage amplitude at the proposed converter can be extended for ultrahigh voltage gain by employing multiple CLSC units.

## References

- [1] H. Liu, H. Hu, H. Wu, Y. Xing, and I. Batarseh, "Overview of high-step-up coupled-inductor boost converters," *IEEE J. Emerg. Sel. Topics Power Electron.*, vol. 4, no. 2, pp. 689–704, Jun. 2016.
- [2] V. A. K. Prabhala, P. Fajri, V. S. P. Gouribhatla, B. P. Baddipadiga, and M. Ferdowsi, "A DC-DC converter with high voltage gain and two input boost stages," *IEEE Trans. Power Electron.*, vol. 31, no. 6, pp. 4206–4215, Jun. 2016.
- [3] H. Liu and F. Li, "A novel high step-up converter with a quasi-active switched-inductor structure for renewable energy systems," *IEEE Trans. Power Electron.*, vol. 31, no. 7, pp. 5030–5039, Jul. 2016.
- [4] A. Abramovitz, B. Zhao, and K. M. Smedley, "High-gain single-stage boosting inverter for photovoltaic applications," *IEEE Trans. Power Electron.*, vol. 31, no. 5, pp. 3550–3558, May 2016.
- [5] B. Macy, Y. Lei, and R. Pilawa-Podgurski, "A 1.2 MHz, 25 V to 100 V GaN-based resonant Dickson

- switched-capacitor converter with 1011 W/in<sup>3</sup> (61.7 kW/L) power density," in *Proc. IEEE Appl. Power Electron. Conf. Expo.*, 2015, pp. 1472–1478.
- [6] H. C. Liu and F. Li, "Novel high step-up DC-DC converter with an active coupled-inductor network for a sustainable energy system," *IEEE Trans. Power Electron.*, vol. 30, no. 12, pp. 6476–6482, Dec. 2015.
- [7] A. Ajami, H. Ardi, and A. Farakhor, "A novel high step-up DC/DC converter based on integrating coupled inductor and switched-capacitor techniques for renewable energy applications," *IEEE Trans. Power Electron.*, vol. 30, no. 8, pp. 4255–4263, Aug. 2015.
- [8] K. C. Tseng, J. T. Lin, and C. C. Huang, "High step-up converter with three-winding coupled inductor for fuel cell energy source applications," *IEEE Trans. Power Electron.*, vol. 30, no. 2, pp. 574–581, Feb. 2015.
- [9] Y. Ye, K. W. E. Cheng, J. Liu, and K. Ding, "A step-up switched-capacitor multilevel inverter with self-voltage balancing," *IEEE Trans. Ind. Electron.*, vol. 61, no. 12, pp. 6672–6680, Dec. 2014.
- [10] L. He, "A novel quasi-resonant bridge modular switched-capacitor converter with enhanced efficiency and reduced output voltage ripple," *IEEE Trans. Power Electron.*, vol. 29, no. 4, pp. 1881–1893, Apr. 2014.
- [11] X. Hu and C. Gong, "A high voltage gain DC-DC converter integrating coupled-inductor and diode-capacitor techniques," *IEEE Trans. Power Electron.*, vol. 29, no. 2, pp. 789–800, Feb. 2014.
- [12] K. C. Tseng and C. C. Huang, "High step-up high-efficiency interleaved converter with voltage multiplier module for renewable energy system," *IEEE Trans. Power Electron.*, vol. 61, no. 3, pp. 1311–1319, Mar. 2014.
- [13] M. Uno, "High step-down converter integrating switched capacitor converter and pwm synchronous buck converter," in *Proc. 35th Int. Telecom-mun. Energy Conf. 'Smart Power Efficiency'*, Hamburg, Germany, 2013, pp. 1–6.
- [14] Y. Ye and K. W. E. Cheng, "A family of single-stage switched-capacitor-inductor PWM converters," *IEEE Trans. Power Electron.*, vol. 28, no. 11, pp. 5196–5205, Nov. 2013.
- [15] Y. P. Hsieh, J. F. Chen, T. J. Liang, and L. S. Yang, "Novel high step-up DC-DC converter for distributed generation system," *IEEE Trans. Ind. Electron.*, vol. 60, no. 4, pp. 1473–1482, April 2013.
- [16] T. J. Liang, S.-M. Chen, L. S. Yang, J. F. Chen, and A. Ioinovici, "Ultra large gain step-up switched-capacitor DC-DC converter with coupled inductor for alternative sources of energy," *IEEE Trans. Circuit Syst.*, vol. 59, no. 4, pp. 864–874, Apr. 2012.
- [17] Y.-P. Hsieh, J.-F. Chen, T.-J. Liang, and L.-S. Yang, "Novel high step-up DC-DC converter with coupled-inductor and switched-capacitor techniques," *IEEE Trans. Ind. Electron.*, vol. 59, no. 2, pp. 998–1007, Feb. 2012.
- [18] Y. P. Hsieh, J. F. Chen, T. J. Liang, and L. S. Yang, "Novel high step-up DC-DC converter with coupled-inductor and switched-capacitor techniques for a sustainable energy system," *IEEE Trans. Power Electron.*, vol. 26, no. 12, pp. 3481–3490, Dec. 2011.