



A Microgrid Based on Wind Driven DFIG and PV Array with Boost Converter for Optimal Fuel Consumption

Upnesh Kumar¹, Anula Khare² and Vasant Acharya³

Research Scholar, Department of Electrical and Electronics TIT BHOPAL(MP)¹

Associate Professor Department of Electrical and Electronics TIT BHOPAL(MP)^{2,3}

Abstract: In this paper a micro grid is introduced with PVA and battery connected to DFIG for energy sharing. This paper presents a green energy solution to a microgrid for a location dependent on a diesel generator (DG) to meet its electricity requirement. This microgrid is powered by two renewable energy sources namely wind energy using doubly fed induction generator (DFIG) and solar photovoltaic (PV) array. The extraction of maximum power from both wind and solar, is achieved through rotor side VSC control and bidirectional buck/boost DC-DC converter control, respectively. The microgrid is modelled and simulated using Sim Power Systems toolbox of MATLAB, for various scenarios such as varying wind speeds, varying insolation, effect of load variation on a bidirectional converter and unbalanced nonlinear load connected at point of common coupling (PCC). The DFIG stator currents and DG currents, are found balanced and sinusoidal. The model is further updated with DC-DC boost converter connected to PVA for maximum power extraction controlled by MPPT algorithm.

Keywords: Wind Turbine, doubly fed induction generator (DFIG), diesel generator, solar photovoltaic array, bidirectional buck/boost DC-DC converter, battery energy storage, power quality.

1. Introduction

1.1 Microgrid

Microgrids are emerging as an integral feature of the future power systems shaped by the various smart-grid initiatives. A microgrid is formed by integrating loads, distributed generators (DG) and energy storage devices. Microgrids can operate in parallel with the grid, as an autonomous power island or in transition between grid-connected mode and islanded mode of operation.

The microgrid concept, involving small transmission and distribution (T&D) networks, efficiently makes use of all the location specific distributed generations (DGs) and distributed energy resource (DERs). These are self-sustained power systems mainly based on loads fed through radial distribution systems and can operate either interconnected to the main distribution grid, or even in

isolated mode. The microgrids advantages are as follows: i) provide good solution to supply power in case of an emergency and power shortage during power interruption in the main grid, ii) plug and play functionality is the features for switching to suitable mode of operation either grid connected or islanded operation, provide voltage and frequency protection during islanded operation and capability to resynchronize safely connect microgrid to the grid, iii) can independently operate without connecting to the main distribution grid during islanding mode, all loads have to be supplied and shared by distributed generations. Microgrid allows integration of renewable energy generation such as photovoltaic, wind and fuel cell generations. After implementation, all the advantages of a microgrid may not become apparent right away because of higher cost of energy as compared to the cost of grid power. [4]

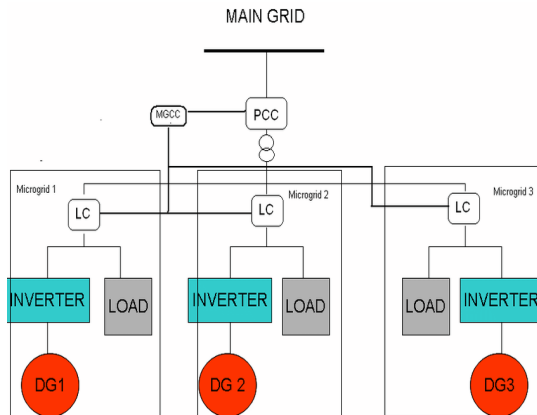

Figure 1: Block diagram of Microgrid

1.2 Maximum Power Point Tracking

Maximum power point tracking (MPPT) is a technique used with wind turbines and photovoltaic (PV) solar systems to maximize power output. To put it simply, they convert a higher voltage DC output from solar panels (and a few wind generators) down to the lower voltage needed to charge batteries. MPPT plays an important role in photovoltaic system because they maximize the power output from a PV system for a given set of conditions, and therefore maximize the array efficiency.

Maximum power point is the voltage and current at which the PV module can produce maximum available power. The IPV- VPV characteristic is non-linear and varies with solar irradiation. Now, consider the power-voltage a characteristic of the PV panel. There is a unique point on the IPV- VPV or PV curve called the maximum power point (MPP) at which the entire PV system operates with maximum efficiency and produces its maximum output power. The location of MPP is not known, but it can be located either through calculation models or by search algorithms. There are many algorithms for implementing MPPT, among those Perturb and Observe method (P&O) & Incremental Conductance method (IC) are the most popular algorithms. The algorithm we use here is a modified version of incremental conductance method. In incremental conductance method the array terminal voltage is always adjusted according to the MPP voltage it is based on the incremental and instantaneous conductance of the PV module. Among the MPPT algorithms implemented in TEG systems, perturb and observe (P&O) and open circuit voltage (OCV) methods are the most widely used. The P&O algorithm falls under the category of a hill climbing algorithm. Hill climbing algorithms are named so due to the algorithm taking steps over sampled data to reach a desired

value, in the case of the P&O this takes steps towards the MPP by increasing or decreasing the duty cycle. A boost converter with variable output voltage and a new maximum power point tracking (MPPT) scheme is proposed which improves the efficiency by 10%. In this study, a modified P&O algorithm is proposed. Simulations and experiments are conducted to evaluate the tracking efficiency of the proposed system [3].

1.3 Perturb and Observe (P&O) Method

The most commonly used MPPT algorithm is P&O method. This algorithm uses simple feedback arrangement and little measured parameters. In this approach, the array voltage is periodically given a perturbation and the corresponding output power is compared with that at the previous perturbing cycle. The perturbation and observation method measures ΔP and ΔV to judge the momentary operating region and then according to the region, the reference voltage is increased or decreased such that the systems operate close to the maximum power point. As the method increases or decreases only the reference voltage, the implementation is simple. However, the method cannot readily track immediate and rapid changes in environmental conditions. The algorithm can be easily understood by the following flow chart:

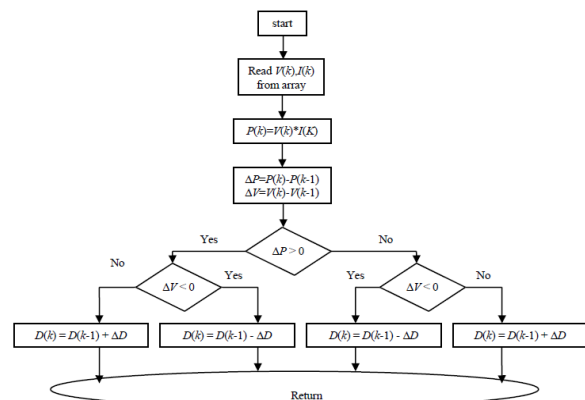

Figure 2: Flow Chart of P&O Algorithm

In P&O algorithm, if increasing the voltage increases the output power, the system continues increasing the operating voltage until the power output attains a maximum value (MPP) and starts to decrease. Once the power output decreases, the voltage is decreased to get back towards the MPP. This Perturbation continues indefinitely, the power output value oscillates around the MPP and never stabilizes, and is considered as the major drawback of P&O algorithm [4-5].

1.4 DC-DC Converter

DC –DC converters are power electronic circuits that convert a dc voltage to a different voltage level. There are different types of conversion method such as electronic, linear, switched mode, magnetic, capacitive. The circuits described in this report are classified as switched mode DC-DC converters. These are electronic devices that are used whenever change of DC electrical power from one voltage level to another is needed. Generically speaking the use of a switch or switches for the purpose of power conversion can be regarded as an SMPS. From now onwards whenever we mention DC-DC converters we shall address them with respect to SMPS. A few applications of interest of DC-DC converters are where 5V DC on a personal computer motherboard must be stepped down to 3V, 2V or less for one of the latest CPU chips; where 1.5V from a single cell must be stepped up to 5V or more, to operate electronic circuitry. In all of these applications, we want to change the DC energy from one voltage level to another, while wasting as little as possible in the process. In other words, we want to perform the conversion with the highest possible efficiency. DC-DC Converters are needed because unlike AC, DC can't simply be stepped up or down using a transformer. In many ways, a DC-DC converter is the DC equivalent of a transformer. They essentially just change the input energy into a different impedance level. So whatever the output voltage level, the output power all comes from the input; there is no energy manufactured inside the converter. Quite the contrary, in fact some is inevitably used up by the converter circuitry and components, in doing their job[6].

2. Methodology

2.1 DC-DC Boost Converter

A boost converter is a DC-to-DC power converter with an output voltage greater than its input voltage. It is a class of switched-mode power supply (SMPS) containing at least two semiconductor switches (a diode and a transistor) and at least one energy storage element, a capacitor, inductor, or the two in combination. Filters made of capacitors (sometimes in combination with inductors) are normally added to the output of the converter to reduce output voltage ripple. The key principle that drives the boost converter is the tendency of an inductor to resist changes in current by creating and destroying a magnetic field. In a boost converter, the output voltage is always higher than the input voltage. A schematic of a boost power stage is shown in the figure mentioned above.

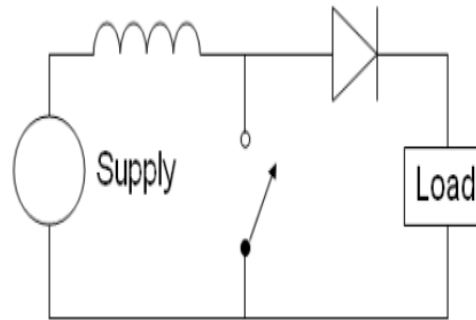

Figure 3 : The basic schematic of boost converter

When the switch is closed, current flows through the inductor in clockwise direction and the inductor stores some energy by generating a magnetic field. Polarity of the left side of the inductor is positive.

When the switch is opened, current will be reduced as the impedance is higher. The magnetic field previously created will be destroyed to maintain the current flow towards the load. Thus, the polarity will be reversed (means left side of inductor will be negative now). As a result, two sources will be in series causing a higher voltage to charge the capacitor through the diode D.

If the switch is cycled fast enough, the inductor will not discharge fully in between charging stages, and the load will always see a voltage greater than that of the input source alone when the switch is opened. Also while the switch is opened, the capacitor in parallel with the load is charged to this combined voltage. When the switch is then closed and the right hand side is shorted out from the left hand side, the capacitor is therefore able to provide the voltage and energy to the load. During this time, the blocking diode prevents the capacitor from discharging through the switch. The switch must of course be opened again fast enough to prevent the capacitor from discharging too much.

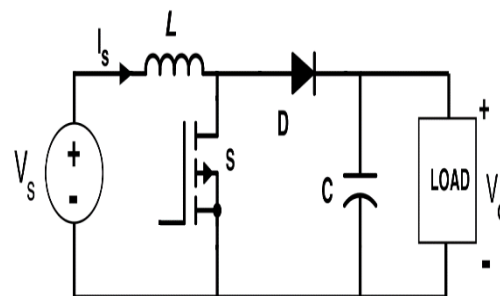

Figure 4: Boost converter Schematic

3. Simulation Results

The proposed system with DFIG connection to grid is shown in the figure given below.

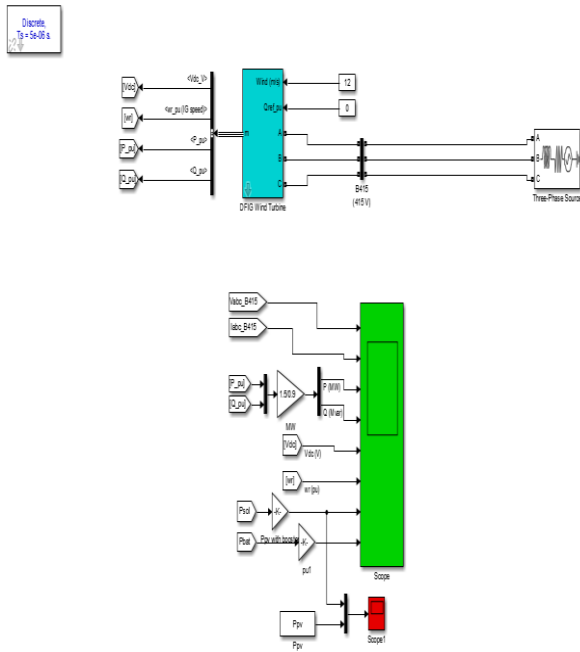

Figure 5: Proposed system with DFIG connection to Grid

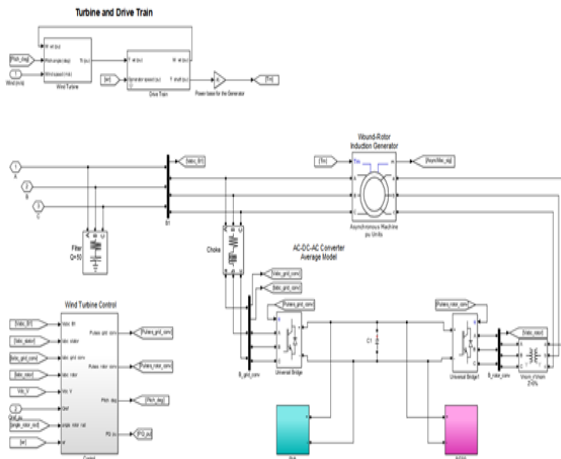

Figure 6: DFIG internal modeling

As seen in the above system the wound rotor induction machine is connected with back-to-back VSI converters through a DC link capacitance. The DC link is further added with PVA and battery module for power sharing along with

the DFIG module. The below is the Line side VSI converter control modelling followed by rotor side converter control modelling. The below is the PVA module which is directly connected to the DC link with no converter.

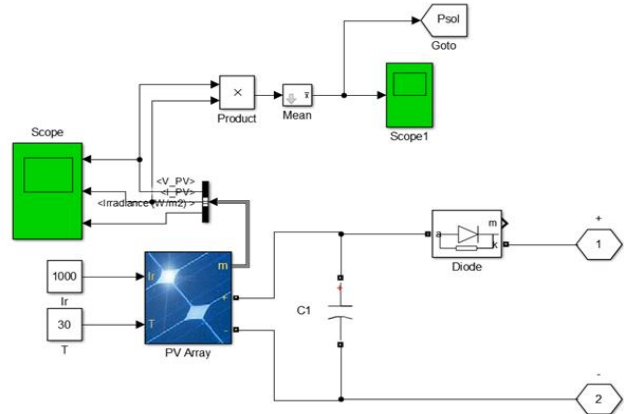

Figure 7: PV module internal modelling

The below is the modeling of the battery storage module with DC-DC bidirectional converter controlling the charging and discharging of the battery. The charge control is done by the below control structure modelled with reference to solar power generated.

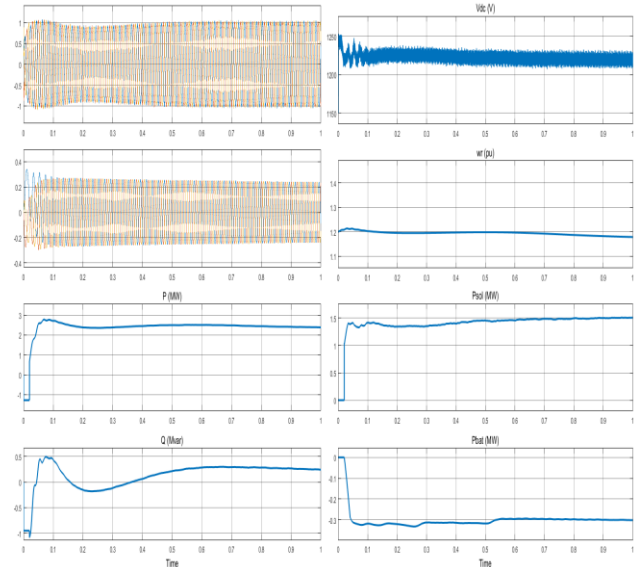

Figure 8: Generated results of the proposed system

The PCC voltage seen is maintained at 1pu and the total power injected by the DFIG module with PVA and battery storage module is 2.5MW. The reactive power is settled to 0MVAR gradually as there is no exchange of reactive power between the modules. The DC link voltage is

maintained at 1200V and the speed of the machine is maintained above synchronous speed (1pu). The PVA power generated without MPPT is noted at 1.5MW and the battery is charging with 0.3MW represented in negative direction.

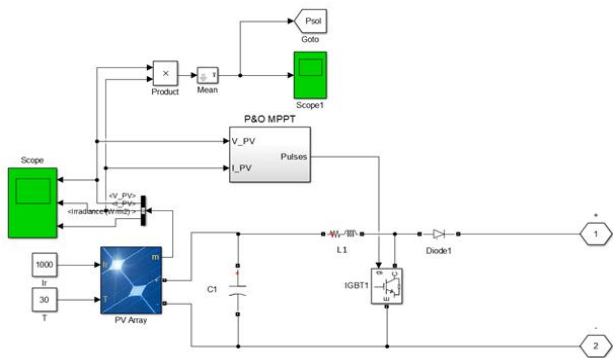

Figure 9: Modified PVA module with DC-DC booster converter

The above is the modification to the PVA module updated with DC-DC booster converter controlled by P&O MPPT for maximum power extraction. With this updated the simulation is run and the below results are recorded.

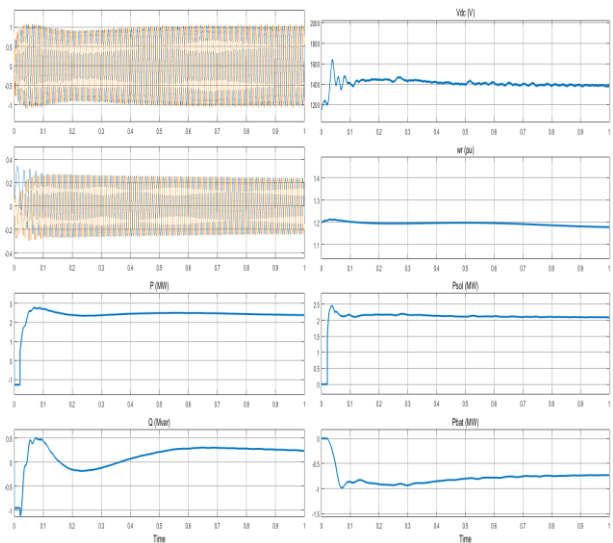

Figure 10: Generated results of the proposed system with PVA booster converter module

As seen in the above figure all the results are similar to the previous system with only change in the PVA power extraction. The power extracted by the DC-DC booster converter MPPT module is noted at 2.1MW which was

previously noted at 1.5MW without DC-DC booster converter MPPT module. The comparison of the PVA extracted power is shown below with units in MW.

4. Conclusion

The microgrid based on wind turbine driven DFIG, DG and solar PV array with BES, with minimum number of converters, has been presented. The solar PV array is directly connected to DC link of back-back connected VSCs, whereas BES is connected through a bidirectional buck/boost DC-DC converter. The system has been simulated for various scenarios such as variable wind speeds, variable insolation and unbalanced nonlinear load connected at PCC. Moreover, the performance of bidirectional buck/boost DC-DC converter at change in the load has been investigated. Simulated results have shown the satisfactory performance of the system to achieve optimal fuel consumption.

References

- [1] V. R. Kolluru, R. K. Patjoshi, and R. Panigrahi, "A Comprehensive Review on Maximum Power Tracking of a Photovoltaic System Under Partial Shading Conditions," vol. 9, no. 1, 2019.
- [2] D. O. Johnson and A. A. Ogunseye, "Grid-Connected Photovoltaic System Design For Local Government Offices In Nigeria," vol. 36, no. 2, pp. 571–581, 2017.
- [3] G. Sharma, "A Review on Grid-Connected PV System," no. June 2017, 2019, doi: 10.31142/ijtsrd2195.
- [4] S. Alsadi, "applied sciences Status : A Review of Criteria , Constrains , Models , Techniques , and Software Tools," 2018, doi: 10.3390/app8101761.
- [5] J. J. Khanam and S. Y. Foo, "Modeling of a photovoltaic array in MATLAB simulink and maximum power point tracking using neural network," vol. 2, no. 2, pp. 40–46, 2018.
- [6] H. J. El Khozondar, R. J. El Khozondar, K. Matter, and T. Suntio, "A review study of photovoltaic array maximum power tracking algorithms," *Renewables Wind. Water, Sol.*, 2016, doi: 10.1186/s40807-016-0022-8.
- [7] S. Connors, "Design and Implementation of a Solar Power System in Rural Haiti by Certified by Design and Implementation of a Solar Power System in Rural Haiti," 2004.
- [8] G. Shahgholian, "A brief review on microgrids: Operation, applications, modeling, and control," *Int. Trans. Electr. Energy Syst.*, vol. 31, no. 6, pp. 1–28, 2021, doi: 10.1002/2050-7038.12885.
- [9] A. Tetuko, "Analisis Kinerja Maximum Power Point Tracker (MPPT) Pada Sistem Photovoltaic Standalone Berbasis Algoritme Perturb And Observe (P & O)," vol. 8,



- no. 2, pp. 72–75, 2021.
- [10] K. S. Patel and V. H. Makwana, “Performance Investigation of Grid-Connected DFIG using Integrated Shunt Active Filtering Capabilities,” *E3S Web Conf.*, vol. 184, no. January, 2020, doi: 10.1051/e3sconf/202018401041.
- [11] M. asif; D. sardar Ali, “POWER QUALITY OF A SMART GRID USING,” vol. 11, no. 2, pp. 95–105, 2020.
- [12] I. T. MUSSA, “Design and Analysis of Dc-Dc Multilevel Boost Converter,” no. February, 2019.
- [13] M. Dalla Vecchia, J. Melo de Andrade, N. Colombo Dal Pont, A. Luis Kirsten, and T. Brunelli Lazzarin, “Proposal, Analysis and Experimental Verification of Nonisolated DC-DC Converters Conceived from an Active Switched-Capacitor Commutation Cell,” *Eletrônica de Potência*, vol. 24, no. 4, pp. 403–412, 2019, doi: 10.18618/rep.2019.4.0031.
- [14] A. Dida, “Adaptive P & O Control for MPPT Algorithm in DFIG System using Fuzzy Logic Controller,” no. May, pp. 1–6, 2019.
- [15] S. Ansari, “Assessment of Renewable Energy Sources of Iran,” vol. 6, no. 12, pp. 206–211, 2019.
- [16] A. Muhtadi, A. M. Saleque, and M. A. Mannan, “Solar and wind energy based microgrid: Study of architecture’s potential at coastal areas in Bangladesh,” *AIUB J. Sci. Eng.*, vol. 17, no. 2, pp. 31–36, 2018, doi: 10.53799/ajse.v17i2.6.
- [17] A. Muhtadi and A. M. Saleque, “Modeling and simulation of a microgrid consisting solar PV & DFIG based wind energy conversion system for St. Martin’s island,” 2017 IEEE 3rd Int. Conf. Eng. Technol. Soc. Sci. ICETSS 2017, vol. 2018-Janua, no. August, pp. 1–6, 2018, doi: 10.1109/ICETSS.2017.8324152.
- [18] D. Dhakad and Maurya, “Integrated Renewable Energy System with the use of Battery Energy Storage,” *Int. J. Trend Sci. Res. Dev.*, vol. Volume-2, no. Issue-3, pp. 1261–1265, 2018, doi: 10.31142/ijtsrd11289.
- [19] N. H. Baharudin, T. M. N. T. Mansur, F. A. Hamid, R. Ali, and M. I. Misrun, “Performance Analysis of DC-DC Buck Converter for Renewable Energy Application,” *J. Phys. Conf. Ser.*, vol. 1019, no. 1, 2018, doi: 10.1088/1742-6596/1019/1/012020.
- [20] T. Dobbin, “Modelling and control of a doubly-fed generator with variable speed wind turbine for electromechanical stability studies .,” no. July 2014, 2018.
- [21] S. Priya, M. Marimuthu, S. Vijayalakshimi, and S. P. Perumal, “Modelling and Simulation Of Hybrid (Wind And Solar) For Dc Microgrid,” vol. 9, no. 3, pp. 163–167, 2018.