

# A transformer less single phase fuzzy controlled PVA grid integrated Inverter

Satwant kumar ravi<sup>1</sup>, Prof. Vasant Acharya<sup>2</sup>

Research Scholar, Department of Electrical and Electronics TIT BHOPAL(MP)<sup>1</sup>  
Assistant Professor Department of Electrical and Electronics TIT BHOPAL(MP)<sup>2</sup>

---

**Abstract:** In this paper a single-phase transformer less PVA integrated inverter is connected to the grid with grid voltage synchronization using PLL. The converter is connected with two PVA modules at the input with different irradiation conditions due to shading. As two subarrays are connected in series, the number of serially connected modules within a subarray is reduced to half. Reduction in the number of serially connected PV modules within a subarray leads to an overall improvement in the magnitude of power that can be abstracted from a subarray while the modules of the subarray are exposed to varied atmospheric conditions. The converter is controlled by feedback loop system with specific current references generated by MPPT technique. The topological structure of the inverter ensures that the common mode voltage does not contain high frequency components, thereby reducing the magnitude of leakage current involved with the solar panels well within the acceptable limit. The PI controller is further replaced with fuzzy logic controller for better improvement in power injection. A Simulation analysis is carried out on the converter using MATLAB software.

**Keywords:** Grid connected single phase transformer less PV inverter, Maximum power extraction, Mismatched operating condition, fuzzy logic controller.

---

## 1. Introduction

The primary photovoltaic cells were formed in the late 1950s, and throughout the 1960s were basically used to give electrical capacity to earth circling satellites. In the 1970s, various upgrades in delivering, execution and nature of PV modules reduced costs and paved way for range of chances for fuelling remote earthbound applications, along with battery charging for bearing guides, signals, broadcast communications instrumentation and various basic, low control requirements. During 1980s, photo voltaic emerged as a favored power supply for electronic gadgets, adding machines, lights, watches, radios and diverse little battery-charging applications. Following the 1970s emergency, there was rise in creation of PV control frameworks for private and business utilities and applications. The energy crises of the 1970s, led to the development of PV power systems for residential and business uses. Globally the application of photovoltaic systems to power rural health clinics, refrigeration, water

pumping, telecommunications, and off grid households increased significantly, and accounts for a major portion of the current world marketplace for PV product [1].

### 1.1 PV Cell Concept

A basic Si PV cell comprises of a thin wafer of an ultra-thin layer of phosphorus-doped (N-type) Si on top of a thicker layer of boron-doped (P-type) Si. An electrical field is produced at the surface contact of these two. When sunlight strikes the surface of a PV cell, this electrical field gives energy and excites light-activated electrons, prompting a stream of current through the cell and thereby providing it to the electrical load. Regardless of size, even a small semiconductor PV cell produces about 0.5 – 0.6-volt DC under open-circuit, no-heap conditions. The power yield of a PV cell depends on its proficiency and size and is relative to the force of sunlight falling on the

surface of the cell. For example, below peak sunlight conditions, a typical industrial PV cell with an extent of 160 cm<sup>2</sup> can turn out regarding a pair of watts peak power. If the sunlight intensity were 40 p.c. of peak, this cell would manufacture regarding 0.8 watts.

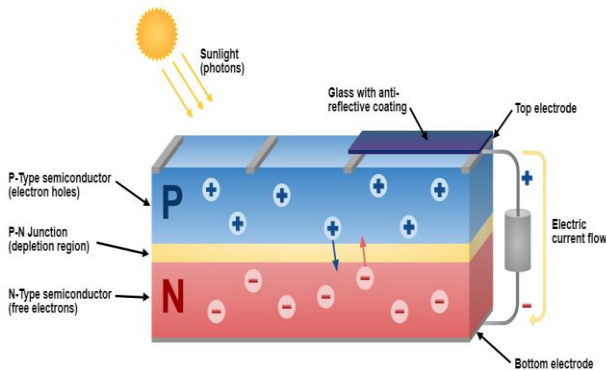

Figure 1 A photovoltaic cell

## 2. Transformer-Less Inverter

Unlike conventional inverters which are built with an internal transformer that synchronizes the DC voltage with the AC output the transformer-less (TL) inverters make use of a computerized multi-step process and electronic components that converts DC to high frequency AC, vice versa, and eventually to a standard-frequency AC. Transformer-less inverter are gaining fame worldwide since its induction [2].

## 3. Proposed Work

The below figure showcases the proposed model of a grid connected transformer-less inverter that controls two PV arrays that operates under various atmospheric conditions. A brief discussion about the components is described below.

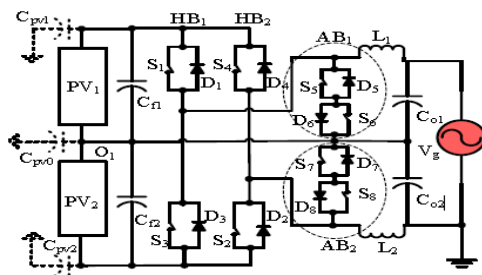

Figure 2 model of grid connected transformer-less inverter Controlling PV arrays

In the above model two serially connected sub arrays (PV1 and PV2) are been individually controlled by the two half bridge inverters (HB1 and HB2) along with respective ac bypass (AB1 and AB2). The components S1, D1, S3 and D3 forms part of one of the half bridge inverter along with its ac bypass components S5, D5, S6 and D6. The other half bridge components are S2, D2, S4 and D4 along with its ac bypass components S7, D7, S8 and D8. L1 and C01 as well as L2 and C02 acts as output filter of both the inverters respectively. Cf1 and Cf2 are input filter capacitors. Cpv0, Cpv1 and Cpv2 are PV array to ground parasitic capacitors.

The power abstracted by the PV arrays is fed to the grid via the inverter. The inverter helps in providing power to grid at unity power factor taking into consideration MPP, insolation level, temperatures and other atmospheric conditions.

## 4. Fuzzy Logic Controller

Fuzzy logic or fuzzy set theory was given by Lotfi Zadeh, a computer scientist at University of California, Berkeley, in 1965, for representing and manipulating data that is not precise and rather fuzzy or vague. In the beginning he was criticized by the professional community, but progressively, Fuzzy logic (FL) gained importance in the professional society and in due course emerged as a new order of Artificial Intelligence. The FL became a attractive area of research because it worked really well between significance and precision, that for a very long time humans have been doing manually. Fuzzy control gives a formal method to represent, manipulate and implement human's heuristic knowledge regarding the control of a system. The slab diagram of a fuzzy logic controller, in which there is an embedded a closed-loop control system is discussed below. The process outputs are indicated by  $y(t)$ ; its inputs are indicated by  $u(t)$ ; and the reference input to the fuzzy controller is indicated by  $r(t)$ . The fuzzy controller has got four main components: The rule-base, that holds the knowledge in the pattern of a set of rules that, describes the finest way for a system control. The membership functions are used to quantify knowledge. The inference mechanism states control rules which are relevant next to the present time and then decides which input of the plant should be enabled. The fuzzification interface modifies the inputs, such a way that they can be interpreted and compared to the rules in the rule-base. The defuzzification interface transforms the conclusions reached by the inference mechanism into the inputs of the plant.

**Advantages of Fuzzy Control**

The advantages of fuzzy control over the adaptive control can be summed as follows:

- It shares output to input, without much perceptive of all the variables, allowing the design of system to be more precise and even than the conventional control system.
- the linguistic, not numerical; variables make the process similar to that of human thinking process.

**5. Simulation Results and Discussion**

In order to demonstrate the viability of the proposed scheme, detailed experimental studies are carried out utilizing a 1 kW laboratory prototype of the scheme fabricated for the purpose. The pertinent parameters related to the prototype are given in above mentioned table.

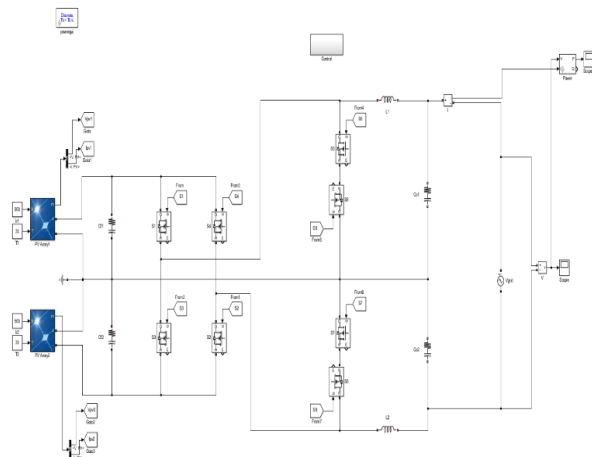

Fig. 3 Proposed topology with grid interconnection

In the above figure the modelling of proposed topology in done in MATLAB Simulink environment. The PVA is available in the library with parameter set as per the given reference paper. The parameters of the single PVA is shown below

The internal modelling of proposed controller with PLL for grid synchronization shown below:

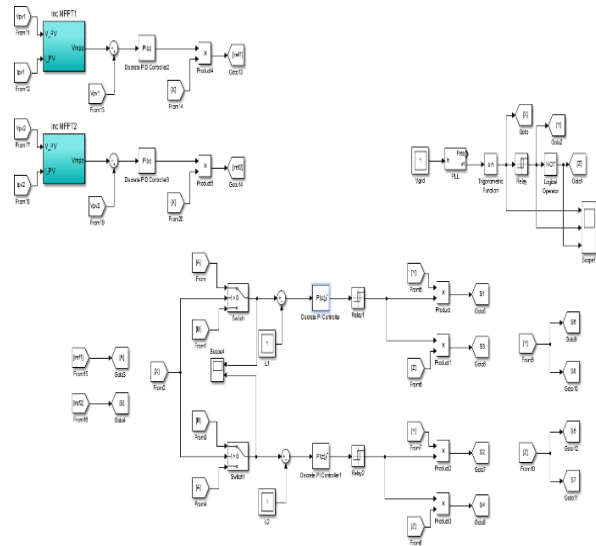

Fig.4 Proposed control structure modelling

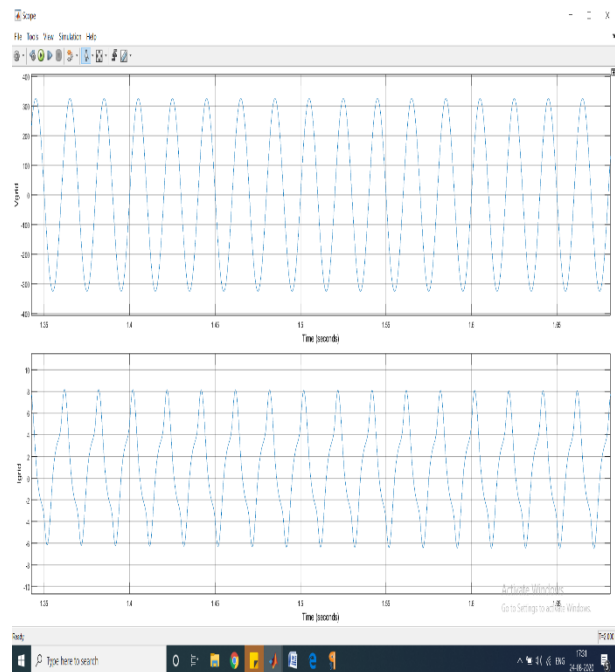

Figure 6 Single phase Grid voltage and current

The above is the grid voltage and current graph with respect to time. The below is the injected power comparison with PI and FIS in the controller. The fuzzy control system injects more power as compared to PI controller. However and increased settling time drawback is seen.

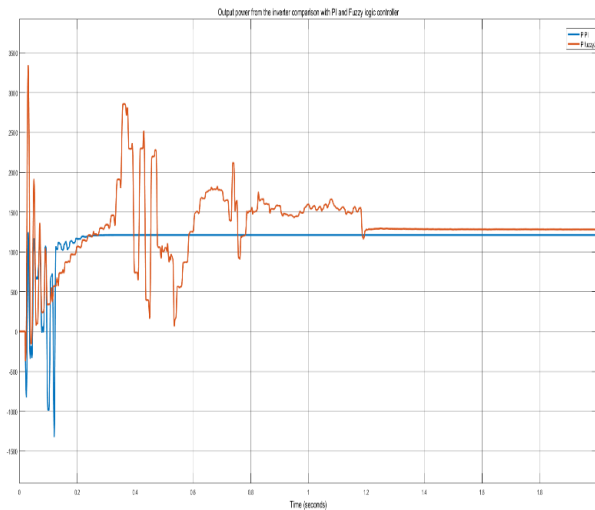

Figure 7 Output power from the inverter comparison

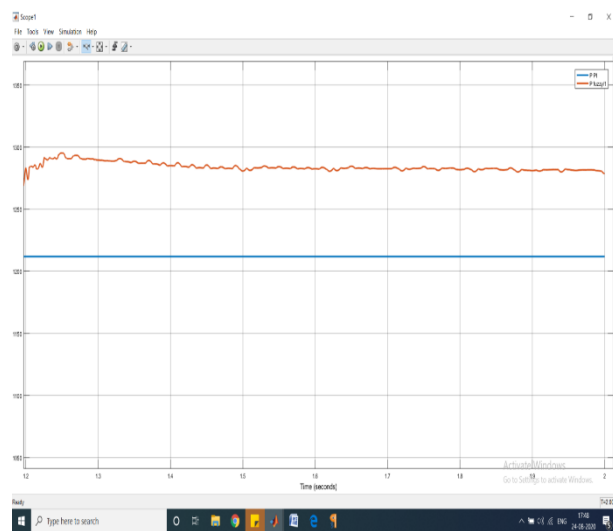

Figure 8 Power injection comparison of fuzzy and PI controller

## 6. Conclusion

As seen the above graphs the power injected by the fuzzy controlled converter is higher than the conventional PI controlled converter. The PVA modules share the power which is injected into the grid with balanced voltage magnitudes. A grid connected single phase transformer less inverter which can extract maximum power from two subarrays during mismatched operating condition. This is achieved by the MPPT technique used in the controller which is generating reference values for the controller.

## References

- [1] D. Debnath and K. Chatterjee, "Maximising power yield in a transformerless single phase grid connected inverter servicing two separate photovoltaic panels," *IET Renewable Power Generation*, vol. 10, no. 8, pp. 1087-1095, 2016.
- [2] U. M. Choi, F. Blaabjerg, and K. B. Lee, "Control strategy of two capacitor voltages for separate MPPTs in photo voltaic systems using neutral-point-clamped inverters," *IEEE Trans. Industry Applications*, vol. 51, no. 4, pp. 3295-3303, Jul/Aug. 2015.
- [3] T. Kerekes, R. Teodorescu, P. Rodriguez, G. Vazquez, and E. Aldabas, "A new high-efficiency single-phase transformerless PV inverter topology," *IEEE Trans. Industrial Electronics*, vol. 58, no. 1, pp. 184-191, Jan. 2011.
- [4] G. M. Masters, *Renewable and efficient electric power systems*, New Jersey: John Wiley & Sons Inc, 2004, ISBN: 0-471-28060-7.
- [5] T. K. S. Freddy, N. A. Rahim, W. P. Hew, and H. S. Che, "Comparison and analysis of single-phase transformerless grid connected PV inverters," *IEEE Trans. Power Electronics*, vol. 29, no. 10, pp. 5358-5369, Oct. 2014.
- [6] T. Kerekes, R. Teodorescu, and U. Borup, "Transformerless photovoltaic inverters connected to the grid," in *IEEE Applied Power Electronics Conference*, pp. 1733-1737, Feb. 2007
- [7] W. Yu, J.S. Lai, H. Qian, and C. Hutchens, "High-efficiency MOSFET inverter with H6-type configuration for photovoltaic nonisolated ACmodule applications," *IEEE Trans. Power Electronics*, vol. 26, no. 4, pp. 1253-1260, Apr. 2011
- [8] B. Ji, J. Wang, and J. Zhao, "High-efficiency single-phase transformerless PV H6 inverter with hybrid modulation method," *IEEE Trans. Industrial Electronics*, vol. 60, no. 5, pp. 2104-2115, May 2013.
- [9] B. Gu, J. Dominic, J. Lai, C. Chen, T. LaBella, and B. Chen, "High reliability and efficiency single-phase transformerless inverter for grid connected photovoltaic systems," *IEEE Trans. Power Electronics*, vol. 28, no. 5, pp. 2235-2245, May 2013.
- [10] L. Zhang, K. Sun, Y. Xing, and M. Xing, "H6 Transformer less Full Bridge PV Grid-Tied Inverters," *IEEE Trans. Power Electronics*, vol. 29, no. 3, pp. 1229-1238, Mar. 2014.
- [11] H. Patel and V. Agarwal, "A single-stage single-phase transformerless doubly grounded grid-connected PV interface," *IEEE Trans. Energy Conversion*, vol. 24, no. 1, pp. 93-101, Mar. 2009.
- [12] Y. Gu, W. Li, Y. Zhao, B. Yang, C. Li and X. He, "transformer less inverter with virtual DC bus concept for cost-effective grid connected PV power systems," *IEEE Trans. Power Electronics*, vol. 28, no. 2, pp. 793-805, Feb. 2013.